

## CLI-1750/LST-1700

# Signal Level, Leakage & Home Wiring Test Kit



Extensive testing shows that one of the main challenges to successfully offering new, digitally based services is the existing wiring in the customer's home. Digital services, including audio, video, Internet, and telephony are less tolerant than traditional analog services of frequency response problems, reflections, group delay, and ingress caused by inferior componetry or poor craftsmanship. Will the existing wiring deliver the quality the customer demands? Should the network provider or homeowner plan to rewire when digital services are activated? You need tools to help answer these questions quickly and accurately because replacing wiring makes new service activation costs high, often limiting the acceptance of new services.

The Model CLI-1750, used in conjunction with the Model LST-1700 Signal Transmitter, helps identify and locate potential problems with the distribution network and home wiring prior to activating these new services. The CLI-1750 and LST-1700 are compact home wiring testers capable of measuring not only routine power levels, but also digital average power, leakage, frequency domain reflectometry (FDR), and sweep, which can be useful for a wide range of

trouble shooting from installation to characterizing existing wire. The instruments' superior user interface and performance can reduce the installation time and repair cost.

Designed for use by installers, the CLI-1750 and LST-1700 are easy to use, portable, and economical solutions that perform a comprehensive set of tests to verify the quality of the installation. With these instruments, signal levels are checked to verify proper levels arriving at the tap and the house according to design and government regulations. Frequency response is measured to verify proper losses as a function of cable length, type, number of passive components, and to uncover any roll-off or sharp changes in response. A FDR test reveals precise location of sources of reflections, degree of severity, and enables surgical replacement of faulty cable or components, or repair of craftsmanship problems. A reverse ingress scan test shows the presence of noise or ingress generated in the home that hampers reverse communication for all customers sharing the node. A leakage test finds potential points of ingress because the source of ingress may not be in operation while the installer is at the house.

- *The Home Wiring Test Kit provides a comprehensive measurement set of tools for troubleshooting home wiring, as well as performing loop loss tests for cable modem installation*
- *Mini-Sweep measures the frequency responses that must be accurate for digital or internet services with the CLI-1750 by receiving LST-1700 sweep signals; frequency characteristics of reverse path can also be obtained*
- *The FDR Mode can identify the location and magnitude of impedance mismatch caused by poor connections, cut wires, bad terminations, providing a distance-to-fault reading with no dead zone*
- *Leakage can be detected and measured with the CLI-1750 by receiving leakage monitoring signals from the LST-1700 transmitter*
- *Combination Signal Level Meter, Leakage Meter and Home Wiring Test, all in one kit*
- *95% of all forward and reverse ingress and interference is located in the distribution and home network. Advanced ingress spectrum scan helps locate the source fast and easy*
- *Complete digital measurement solution for DTV and cable modem signals; digiCheck™ average power measurement including auto limit check*



**ACTERNA™**  
The Keepers of Communications

## Frequency Response Measurement—Mini-Sweep



The LST-1700 generates sweep, which may be inserted at the tap end of the drop or at the ground block, and measured at subscriber terminal locations with the CLI-1750. The installer looks for significant variations in the frequency response which indicate standing waves, excessive loss, roll-offs, or “suck-outs.” The LST-1700 also locates unterminated splitters or taps which may cause microreflections within home wiring. The mini-sweep start/stop frequencies are programmable from 5 to 862 MHz. Users can obtain the frequency characteristics for reverse path since the LST-1700 can transmit in either direction. Mini-sweep is an excellent tool for training installers to perform forward and reverse sweep and preparing them for more advanced maintenance work.

The sweep screen display will show a normalized sweep trace.

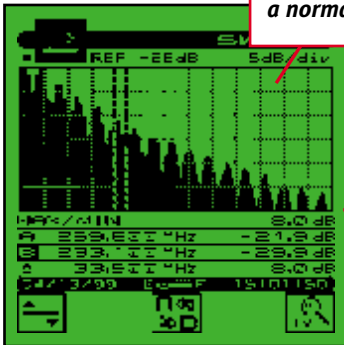

26 dB loss  
30 dB slope  
8dB standing waves

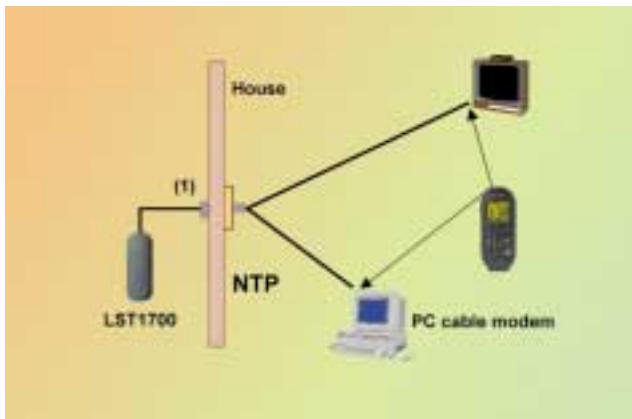

Sweep configuration at a subscriber's premises.

## Fault Location—Distance to Fault



The Model LST-1700 Signal Transmitter provides a source for a frequency domain reflectometry test of in-home wiring to help locate faults. Technicians can measure the location and magnitude of impedance caused by poor connections, cut wires, and bad terminations by using FDR. Mismatch problems can be found effectively and quickly by using this technique.

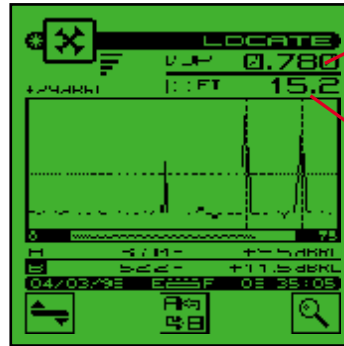

VOP is entered on the keypad or calculated with a known length of cable.

Distance to the fault is calculated using the VOP value.

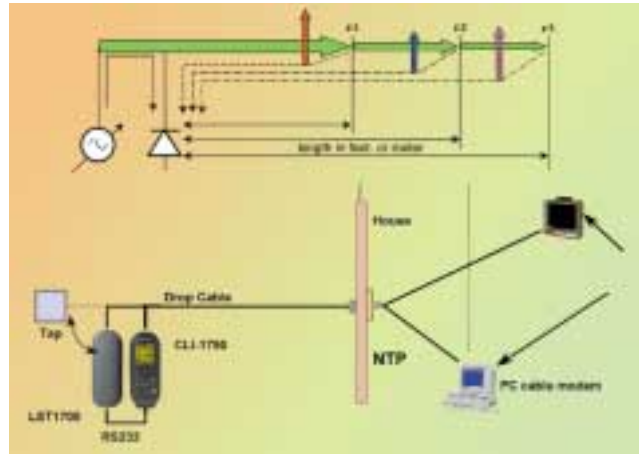

FDR test configuration.

## Ingress is Egress



Ingress is the most serious problem on interactive reverse path services. Ninety-five percent of all ingress comes from the home and distribution network. Leakage and ingress are directly coupled problems. A leak out can also be an opening for ingress to enter the cable system.

## Proactive Leakage Detection in the Home

Leaks can be detected and measured in the home with the CLI-1750 by receiving leakage monitoring signals from the LST-1700 transmitter. The LST-1700 can be used in the CW mode to generate a +30 dBmV leakage test signal. This signal, inserted at the tap or ground block of the home network, can be monitored by the CLI-1750 to locate leaks due to poor connections or faulty components.

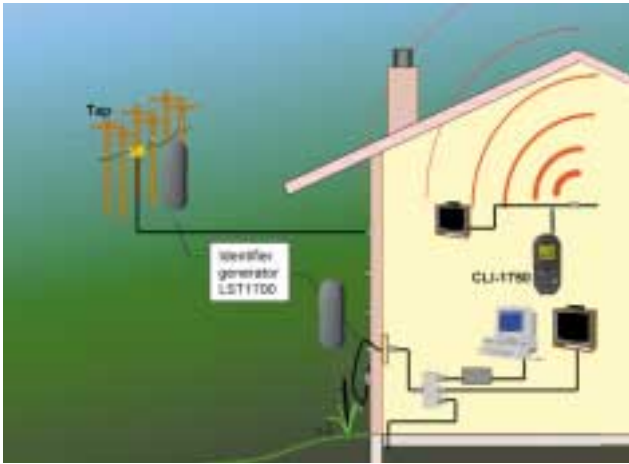

Home leakage detection configuration using the LST-1700 as a signal identifier.

## Leakage Measurement



The flexible configuration menu allows customization of all leakage parameters. Frequency agility allows the user to select any test signal from 115-140 MHz. Leakage alert threshold limits can be set for system or regulatory standards. Visual and audible alarms can be enabled to alert the operator when threshold limits are exceeded. When used with the LT-1000 Leakage Tagger, a special tag alarm can be programmed for use in overbuild situations.



Leakage parameters can be customized in Configure mode.

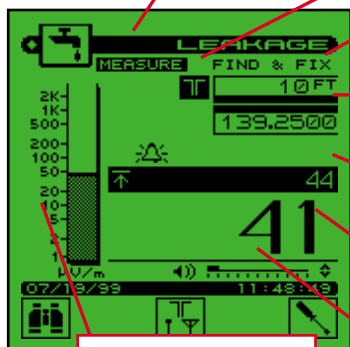

Measurement Mode

Antenna Type

Reference Distance

Measurement Frequency

Peak Hold

Leak Level

Alarm Volume

Analog Meter Scale

The Measurement mode is used for "ride-out" driving applications, calibrated leaks, and FCC/CENELEC testing. A numeric readout and audible alarm quickly alert the user when leakage threshold limits have been exceeded. The leakage measurement is performed on active (unscrambled) video carriers. This mode is more accurate but less sensitive than the Find & Fix mode.

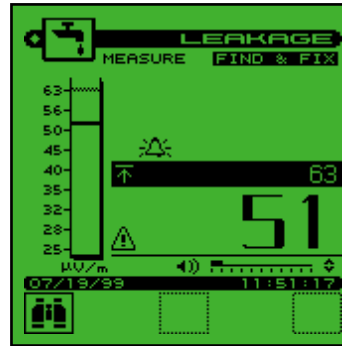

This fast mode is used for drop-to-subscriber and inside the home applications. The fast Find & Fix mode assists in quickly guiding the technician to the leak source. The large, numeric readout quickly updates the leakage signal strength. The graph automatically rescales in the Find & Fix mode providing an easy-to-interpret graphical view of the leak response.

## Directional Hand-held Antenna (HD-1)



The handheld dipole antenna improves directionality and accuracy for pinpointing leakage sources. The HD-1 increases the CLI instrument sensitivity compared to the near field probe antenna. The directivity dynamic

range of the HD-1 is approximately 10-20 dB in an outside environment and approximately 5-10 dB in an indoor environment. It is easier to train new technical staff to understand and operate the CLI System because they get significantly more directionality with the HD-1 and firmware version 6.0 or higher. The HD-1 hand-held dipole antenna picks up RF energy in a directional pattern. This pattern gives directionality that is crucial in locating leaks. With the PL-1 adjustable 10 foot (3 m) pole and adapter, the HD-1 can be used for calibrated leaks and FCC/CENELEC conformance testing.

## LT-1000 Leakage Tagger



The distinctive signal tagging from the LT-1000 assures the technician that detected leaks are not being generated from competing systems in overbuild situations. The Leakage Tagger modulates the video signal under test at user programmable rates, and improves detection sensitivity in noisy environments.



The tagger located at the headend modulates a small signal on the TV carrier and works as a distinctive identifier for the leakage meter.

## Ingress Scan Mode



The Ingress Scan mode displays ingress signals in the forward and reverse band. With the growing implementation of digital carrier transmissions, guarding against ingress becomes more and more important. With the CLI-1750 at the tap (beginning of the drop cable), you can get the total ingress picture of a home. Moving the instrument toward the ingress source (deeper into the home) will eventually help identify the source of ingress.

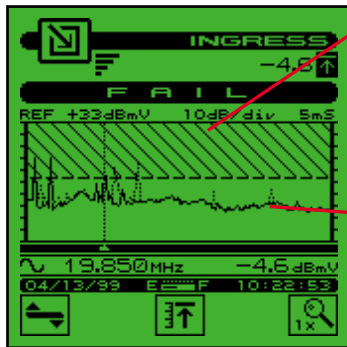

Intermittent ingress captured by peak-hold.

Displays frequency on the X-axis and amplitude on the Y-axis

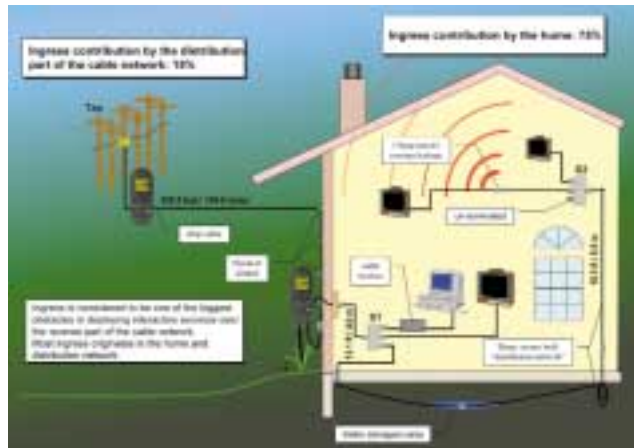

Ingress configuration at tap or ground block.

## Level Measurement



CLI products provide a comprehensive single-channel display and a multi-channel display with pass/fail indicators that quickly and clearly indicates whether all channels are being received at the subscriber's drop at appropriate system design levels.

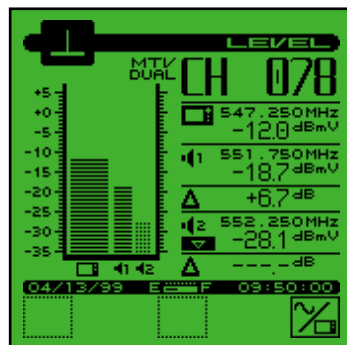

The single-channel display shows the video and audio carrier levels and the difference between levels. (Compatible with dual sound and NICAM.)

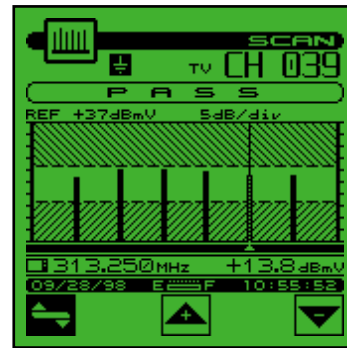

The six-channel scan shows six different user-defined video carriers, with pass/fail indicator for user-defined limits.

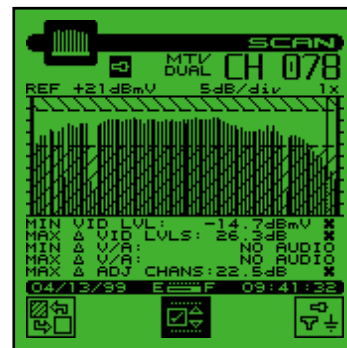

The Full Scan display shows all user-defined video carriers. The unique limit check feature quickly checks the results against user-defined analog and digital limits.

## Installation Check



Pressing the "✓" single key provides an installation status check which allows users to verify that all levels are within user-defined limits. Up to four different limits can be configured: tap, ground block, subscriber drop, and custom. This feature can be used to determine if a subscriber connection meets cable networks or government specifications.



The results are displayed in a list indicating which parameters are out of tolerance. If all levels are within limits, a "✓" appears in the right far column. If any parameter is out of tolerance an "x" will be shown.



Pressing the "Cycle" soft key provides more detail by displaying a list of all channels. Passing channels are indicated by a "✓" in the right hand column.



 Pressing the "Cycle" soft key provides a detailed view of errors by specific channel.

These results can be printed or downloaded to a PC for report generation using StealthWare Data Analysis Software.

## Tilt Mode



Tilt measurement is a fast and effective method to balance line extenders and in-home amplifiers.

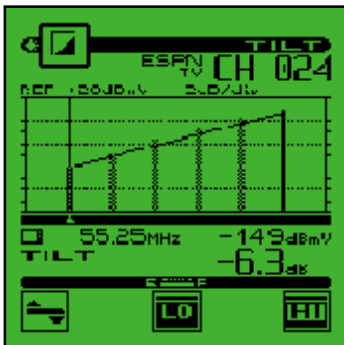

*The tilt display shows six channels and updates in less than a second.*

## Auto Test



To certify that the network termination and home networks are within specifications, or to gather proof-of performance compliance data, an auto-test can be performed. Tests can be executed immediately or scheduled over a period of time. When configuring an Auto Test, technicians can record information about the location at which the test is being performed. Files can be created for commonly tested locations so technicians only need to enter the information once, and a test report can be printed for each interval. Or a comprehensive 24 hour report can be generated to that summarize all data collected from up to four intervals.



*Auto Test results are time, date, and temperature stamped and can be stored, viewed, printed, or uploaded to Acterna's StealthWare software.*

## Customized Channel Plans



Channel plans can be built, stored, edited, and re-used as needed. This convenient feature maximizes efficiency and productivity for technicians use the meter for more than one plant. Users can quickly select the correct channel plan for the current location. A "cloning" function makes it possible to easily transfer channel plans from one field instrument to the other. StealthWare software enables users to upload and download channel plans from PC to meter.

## digiCheck™ Digital Signal Measurement



Making accurate digital average power and performance measurements are addressed with the digiCheck measurement function. The digiCheck average power measurement takes small slices of the integrated RF-energy, summing them together to provide one total power reading. It takes into account the channel flatness of the digital carrier itself.



*Digital-TV and forward cable modem signal.*

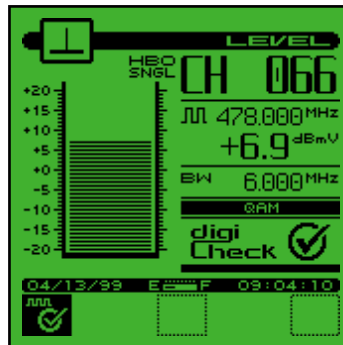

*The digiCheck method of measuring the total integrated RF-power under the haystack is very reliable and accurate. All level readings are fully compensated for by the correct occupied bandwidth.*

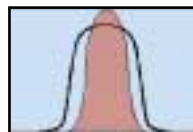

*"Small-band" digital signals are similar to cable telephone carriers.*

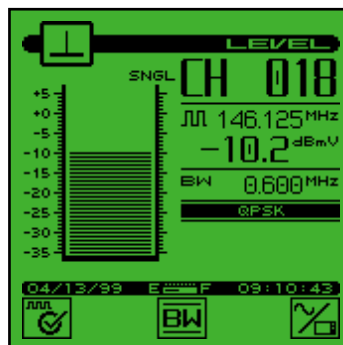

*"Small-band" digital carriers, like cable telephony, require a different measurement technique. For that purpose, the digiCheck feature offers a time average as well. Even in this case, all level readings are fully compensated for by the correct occupied bandwidth.*

## Digital and Analog Limits



Cable networks have analog and digital carriers. The levels of analog and digital signal measurements vary according to standards and regulations. Digital signals are typically 6-14 dB below analog signals. Users can enter minimum and maximum digital channel level limits separately from analog limits. Scan mode, Installation Check, and Auto Test accurately measures both digital and analog signals. This allows easy identification of the pass/fail condition of both channel limits sets.



**In the Configure mode both analog and digital limits can be set to guarantee correct test results.**

## StealthWare Software

Signal level measurements can be uploaded for storage, viewing, and printing. StealthWare allows users to build channel plans and test locations which can be downloaded to the field meter.

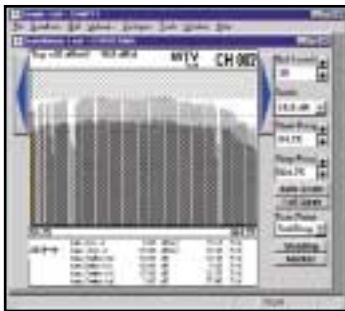

**StealthWare Features for Home Wiring Test Kits:**

- Auto Tests
- Channel Plan
- Locate files/graph
- Sweep
- Ingress Graph
- Installation Test

## Multi-Lingual LCD Screen

The user interface supports seven language options.

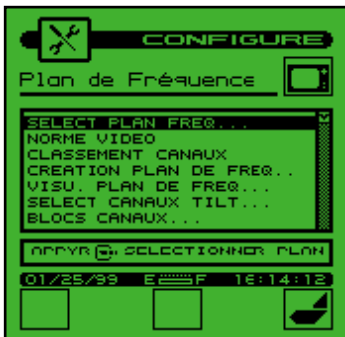

**Available Languages:**

- English
- French
- Portuguese
- German
- Spanish
- Italian
- Dutch

## Specifications

### FREQUENCY-CLI-1750

Range.....5 to 890 MHz  
 Accuracy .....10 ppm @ 25°C (77°F);  
 20 ppm over temp.  
 Tuning Resolution .....25 kHz

### LEVEL MEASUREMENT-CLI-1750

Range.....-20 to +50 dBmV  
 Resolution.....0.1 dB  
 Accuracy.....±0.75 dB Flatness,  
 ±0.75 dB Linearity @ 25°C (77°F)  
 Digital Average Power (optional).....± 2.0 dB (typical)

### SCAN MODE-CLI-1750

Number of Channels .....120  
 Scan Rate.....Approximately 6 carriers/second

### LEAKAGE MODE-CLI-1750

#### Level Measurement

Input Sensitivity (with HD-1 dipole or VMA-3 mag mount)

Video Detection .....From 1 µV with LT1000  
 Leakage Tagger activated  
 (121 to 133.2625 MHz)

CW Detection .....From 0.5 µV typical with LT1000  
 Leakage Tagger activated  
 (121 to 133.2625 MHz)

Measurement .....From 1.4 µV (115 to 140 MHz)

Range .....0.5 to 2,000 µV (at input connector)

#### Accuracy

Measurement .....±1.5 dB @ 25°C (77°F)  
 Find & Fix .....±2.25 dB @ 25°C (77°F)

#### Tuning Carrier

Frequency Range .....115 to 140 MHz range (Video)  
 Accuracy .....10 ppm @ 25°C (77°F);  
 20 ppm over temp.

Resolution .....25 kHz

Tagger modulation for leakage .....Modulation frequency  
 5 to 25 Hz

### FREQUENCY-SWEEP

Range.....5 to 862 MHz  
 Accuracy .....10 ppm @ 25°C (77°F);  
 20 ppm over temp.

Resolution .....25 kHz

LST-1700 Output Level .....+30 dBmV ±/-3 dB (5 to 799MHz)  
 +30 dBmV ±/-4 dB (>799 to 862MHz)

Resolution	# Points	Resolution
Ultra	129	Fstop-Fstrt/129
Maximum	65	Fstop-Fstrt/65
Medium	33	Fstop-Fstrt/33
Minimum	17	Fstop-Fstrt/17

Measurement Level Range .....-20 to +50 dBmV  
 Amplitude Accuracy .....±1 dB (normalized measurement)  
 Amplitude Resolution .....0.1 dB  
 Display Scale .....1, 2, 5, 10, and 20 dB/div.

**SWEEP RATE**

Resolution	Max (sec)	Typical (sec)
Ultra	6.13	5.35
Maximum	3.53	3.13
Medium	1.93	1.73
Minimum	1.33	1.22

**FILE STORAGE CAPACITY–CLI-1750**

241 Kb maximum; dependent upon file type and number of files stored (see below examples).

Files	Number	Storage
Channel Plans	5	11,120
Auto Tests	25	87,175
Installations	26	54,210
Tilt Files	30	5,430
Ingress Files	30	17,640
Sweep Files Ultra	30	25,200
Locate Files Ultra	25	26,925
Location Files	30	2,100
<b>TOTAL</b>	<b>201</b>	<b>229,800</b>

**GENERAL–CLI-1750**

Dimensions .....4.25” (W) x 10” (H) x 2.5” (D)  
 Weight .....1.3 kg (2.9 lb.)  
 Operating Temp. Range .....-10 to +50°C (14 to 122°F);  
 ±3 dB drift, -10 to +50°C  
 Water Resistance .....Meets or exceeds MIL-STD-810D  
 (Method 506.2)

**POWER**

Battery Life .....2.25 hours continuous (backlight off)  
 2.25 hours continuous (backlight off) in Leakage mode  
 replaceable battery cartridge  
 Charge Time Wallcharger .....16 hour charge with unit “off”

**FREQUENCY–LST-1700**

Display .....On accompanying CLI-1750  
 Range .....5 to 862 MHz  
 Accuracy .....10 ppm @ 25°C (77°F);  
 20 ppm over temp.  
 Resolution .....25 kHz  
 Output Level .....+30 dBmV (±3 dB)  
 Amplitude Accuracy .....±1 dB (normalized measurement)  
 Amplitude Resolution .....0.1 dB  
 Sweep Rate .....6.125 sec. max (ultra resolution)

**FREQUENCY DOMAIN REFLECTOMETRY–LST-1700**

Measurement displayed on CLI-1750. Locate rate per resolution:

Resolution	Sweep Points	Rate (sec)
Ultra	1,024	40
Maximum	512	20
Medium	256	10
Minimum	128	5

Frequency Domain Reflectometry Distance Resolution:

Resolution	Footage	Meters
Ultra	0.7 ft	0.2 m
Maximum	1.3 ft	0.4 m
Medium	2.6 ft	0.8 m
Minimum	5.2 ft	1.6 m

@ appropriate distance zoom  
 @ any distance:  
 between 20 ft and 2,679 ft  
 between 6.1 m and 817 m  
 @ Vop=0.82

Distance Accuracy .....Equal to the distance resolution  
 (with constant Vop)  
 Amplitude Accuracy .....±3 dB typical @ 25°C (77°F) w/known  
 cable attenuation factor and ultra resolution  
 Range .....0 to -20 dB

**CW SIGNAL GENERATOR–LST-1700**

Range .....5 to 862 MHz (set in 115 to 140 MHz range  
 for use of CLI-1750 leakage feature)  
 Accuracy .....10 ppm @ 25°C (77°F);  
 20 ppm over temp.  
 Resolution .....25 kHz  
 Output Level .....+30 dBmV

**GENERAL–LST-1700**

Dimensions .....4.25” (W) x 10” (H) x 2.5” (D)  
 Weight .....1.14 kg (2.5 lb.)  
 Operating Temp. Range .....-10 to +50°C (14 to 122°F);  
 ±3 dB drift, -10 to +50°C  
 Water Resistance .....Meets or exceeds MIL-STD-810D  
 (Method 506.2)

**POWER**

Battery Life .....4 hours @ 25°C  
 Charge Time Wallcharger .....16 hour charge with unit “off”

## Ordering Information

### Home Wiring Test Kit

1010-00-0407 Includes a battery cartridge for CLI/LST, dual soft system carrying case for HWTK, one charger/AC adapter, HD-1 handheld dipole antenna (includes 4 ft. [1.2 m] cable), operating manual, and "Monitoring and Measuring Signal Leakage" Booklet. CLI to PC cable and CLI to LST cable.

### Options

1019-00-0599 Digital carrier for measuring the average power of digital signals  
1019-00-0551 Leakage tagger differentiates leaks in overbuilt systems, increases detection range, and limits false alarms

### Optional Accessories

1019-00-1276 Adjustable 10 ft. (3 m) pole with HD-1 adapter (for calibrated leaks and FCC/CENELEC testing) including 12 ft. (4 m) BNC-cable  
1019-00-0478 Vehicle mount "Docking Station" for quick antenna and auxiliary power connection in vehicle  
1019-00-0560 Adjustable arm mount for docking station to enable viewing of display from driver's seat  
1019-00-0532 Magnetic vehicle mount 1/4l whip antenna MBC-4:4-bay battery cartridge charger (CE compliant); charge time, 3 hours  
1019-00-0553 Portable serial thermal fusion printer kit  
1010-00-0340 Data management and analysis software (includes 1019-00-0469, CLI to PC cable)  
1019-00-1284 Durable padded carrying case that fits in the docking station, with storage area for HD-1  
1019-00-0479 Field replace cable CLI-1750/LST-1700 battery cartridge  
4010-00-0119 Charger/Adapter, 120VAC to 12VDC  
1019-00-0554 European Charger/Adapter (CE Compliant)  
1019-00-0558 Charger/Adapter universal input, 12VDC output-CLI-1750  
1019-00-0557 Cigarette lighter adapter  
1019-00-0467 MSCLI printer cable  
1019-00-0468 Generic serial printer cable; CLI to 25 pin male connector  
1019-00-0469 CLI to PC cable  
1019-00-0470 RS232 interconnect cable (included with LST-1700)  
1019-80-0533 Charger/adapter universal input 12VDC output LST-1700  
1019-80-0590 Durable padded carrying case for Model LST-1700  
1217-50-0216 4 ft. (1.2 m) BNC-cable for HD-1  
3010-16-0028 Replacement HD-1 antenna elements  
6510-60-0001 "Monitoring and Measuring RF Signal Leakage" booklet  
1010-00-0474 "Find & Fix RF Signal Leakage" interactive training CD

**Note:** Specifications, terms, and conditions are subject to change without notice.

Copyright 2001, Acterna, LLC, doing business as Acterna. All rights reserved. Acterna and The Keepers of Communications, its logo, and digiCheck are trademarks of Acterna, LLC. All other trademarks are the property of their respective owners.

CNN01560201AE

## Regional Sales Headquarters

**Global Headquarters**  
20400 Observation Drive  
Germantown, Maryland 20876-4023 USA  
Toll Free 1-800-638-2049  
Tel +1-301-353-1550  
Fax +1-301-444-8468  
www.acterna.com

**North America**  
20400 Observation Drive  
Germantown, Maryland 20876-4023 USA  
Toll Free 1-800-638-2049  
Tel +1-301-353-1550  
Fax +1-301-444-8468

**Western Europe**  
Arbachtalstrasse 6  
72800 Eningen u.A.  
Germany  
Tel +49 7121 86 2222  
Fax +49 7121 86 1222

**Latin America**  
Av. Eng. Luis Carlos Berrini  
936 8/9. Andar  
04571-000 Sao Paulo, SP  
Brazil  
Tel +55 11 5503 3800  
Fax +55 11 5505 1598

**Eastern Europe, Middle East & Africa**  
Elisabethstrasse 36  
PO Box 13  
2500 Baden  
Austria  
Tel +43 2252 85 521 0  
Fax +43 2252 80 727

**Asia/Pacific**  
42 Clarendon Street  
PO Box 141  
South Melbourne, Victoria 3205  
Australia  
Tel +61 3 9690 6700  
Fax +61 3 9690 6750

1<sup>st</sup> Neopalimovskiy Per. 15/7 (4<sup>th</sup> floor)  
119121 Moscow  
Russia  
Tel +7 095 248 2508  
Fax +7 095 248 4189



Acterna is present in more than 80 countries. To find your local sales office, go to [www.acterna.com](http://www.acterna.com)



CHEETAH, ACTERNA AND TTC ARE NOW ACTERNA. TO LEARN MORE, VISIT [WWW.ACTERNA.COM](http://WWW.ACTERNA.COM)